

META FORM

PORTFOLIO: RESIDENTIAL ARCHITECTURE

META FORM

INTRODUCTION

Integrated Architectural design approach where architect becomes a developer by partnering up with Real Estate developers to create a better built environment.

Architecture, landscape architecture and interior design are the core services within our firm. We provide modern and contemporary design approaches that respect the environment.

Functional and aesthetic aspects are carefully taken into consideration by our team to create a comprehensive identity for each project.

Our team consists of carefully selected, highly qualified professionals and affiliated firms, who offer strong technical backgrounds and experience in various engineering and design fields.

META FORM

SERVICES

Urban Design
Medical Planning
Green Architecture
Transport Infrastructure



Architectural & Interior Design
BIM
Structural Design
MEP



Real Estate Development
Business Solutions
Market Analysis
Feasibility studies

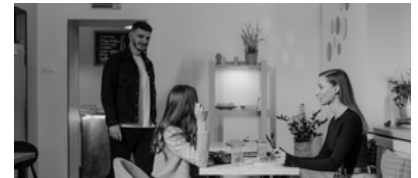

RESIDENTIAL PROJECTS INTERIOR DESIGN

VILLA MR.ABU HAIDAR - 1



COLOR SCHEME

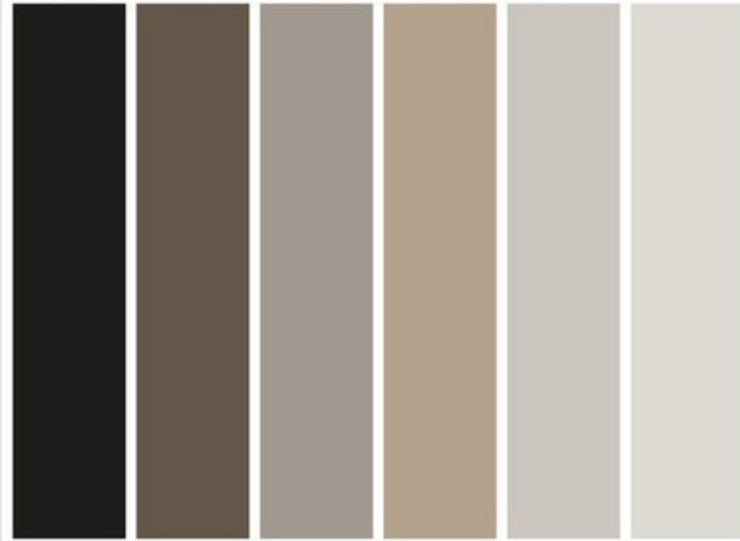

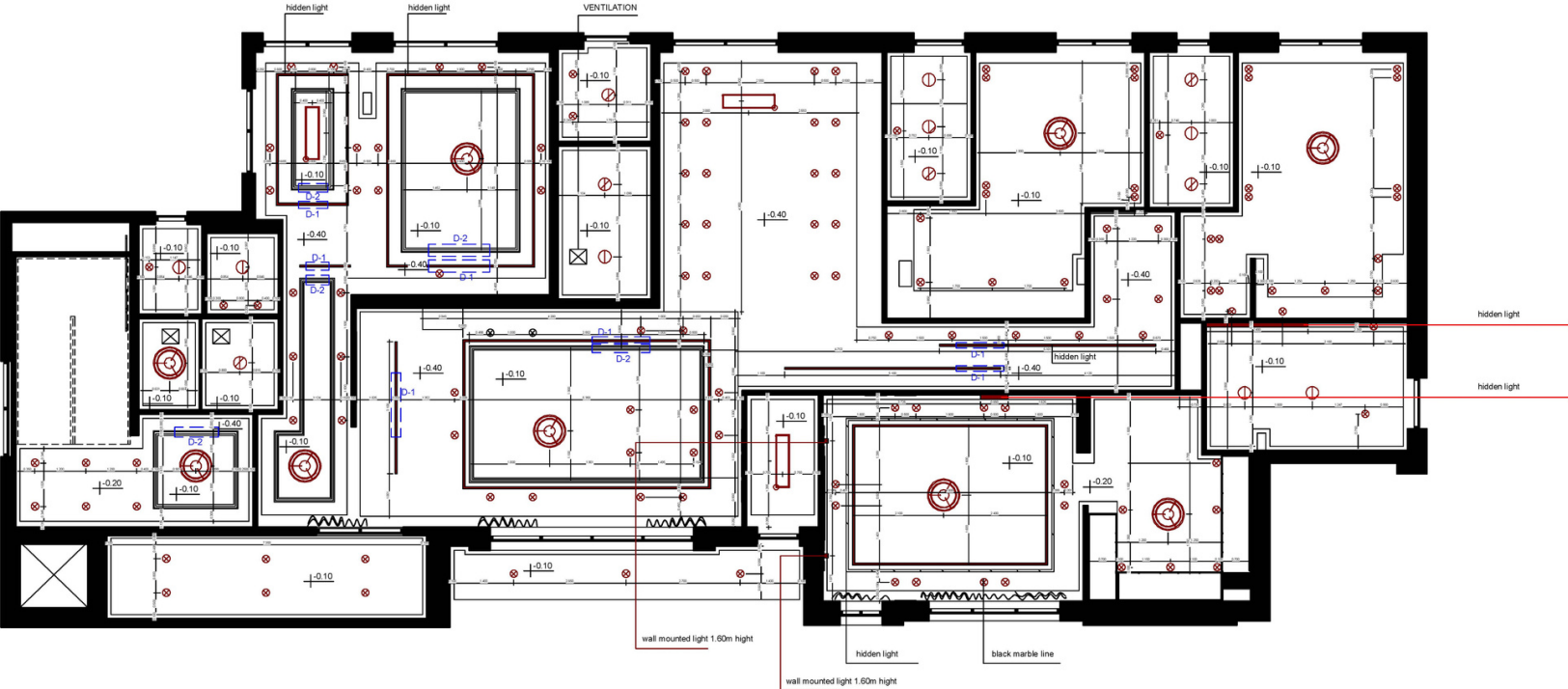

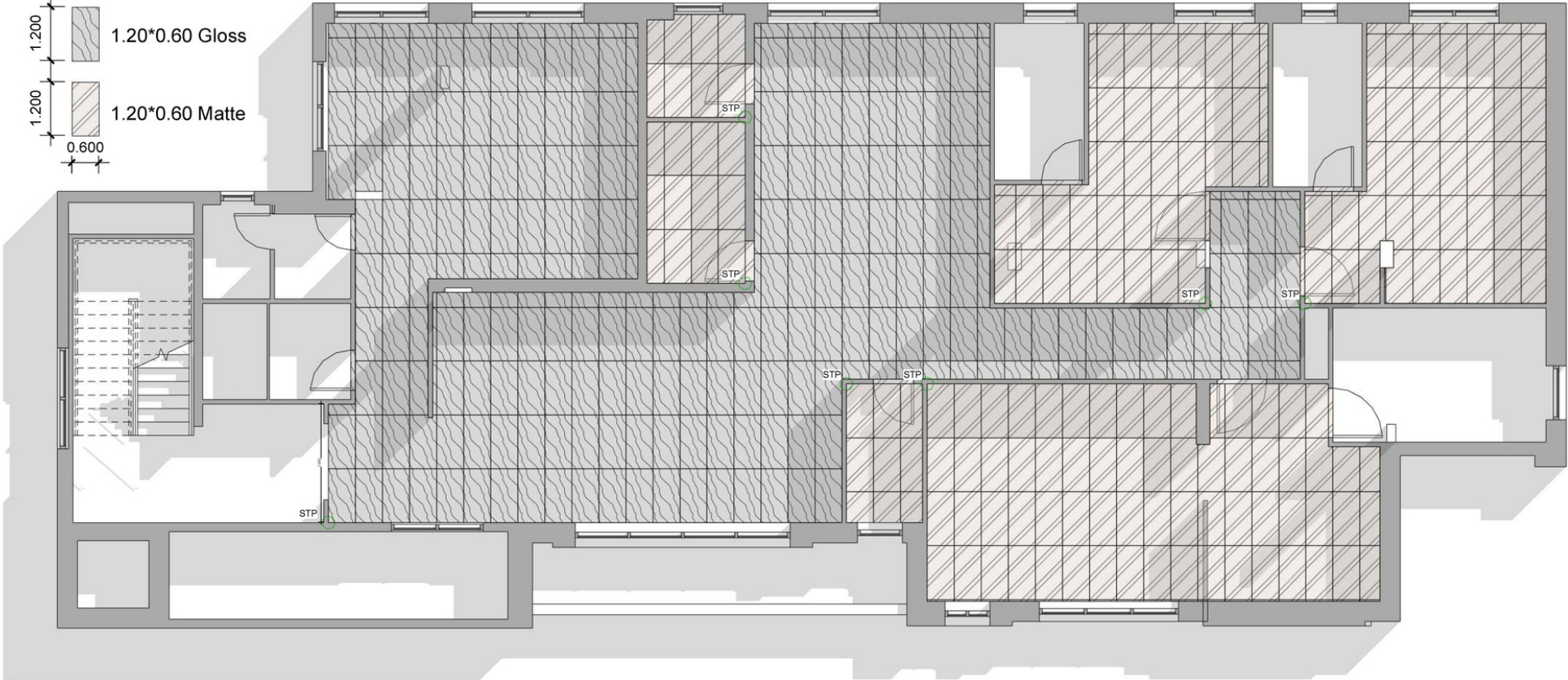
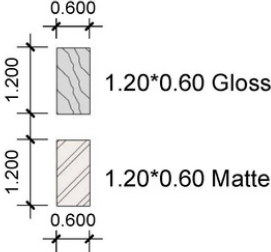

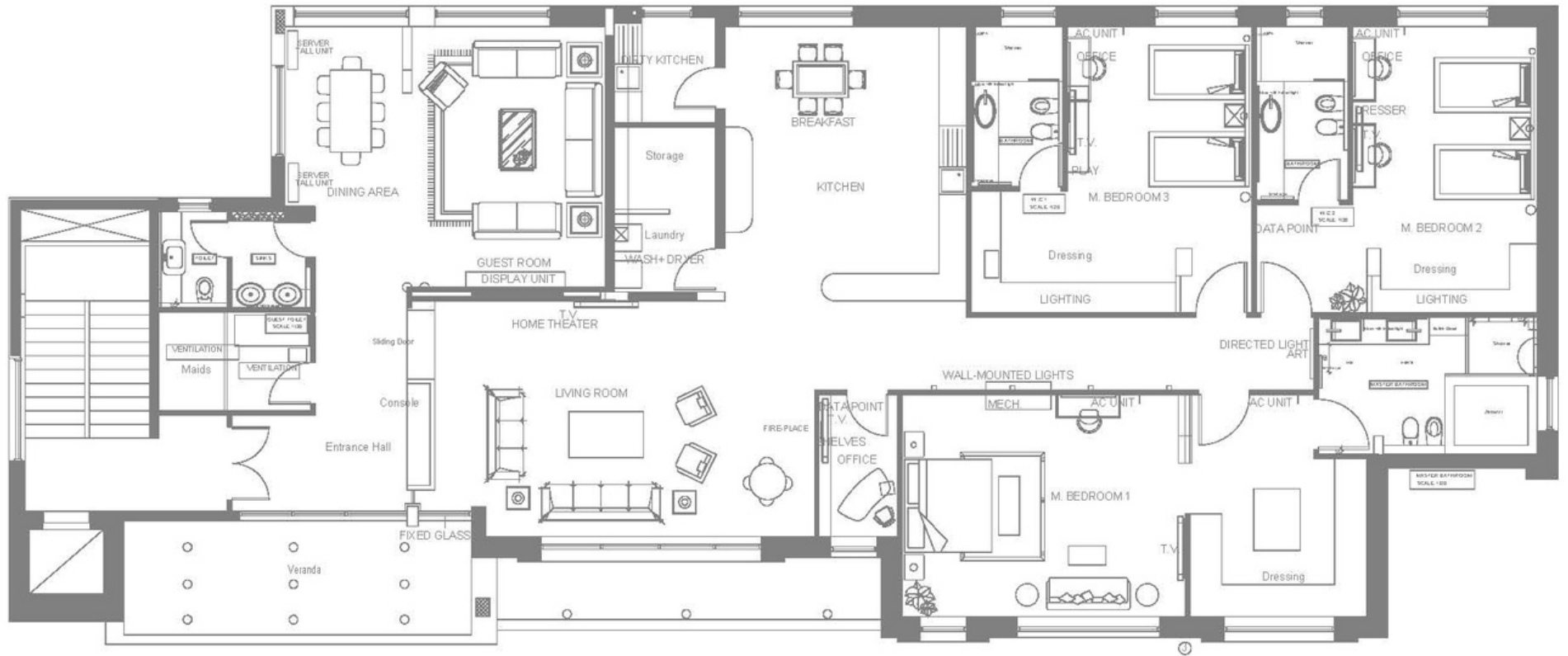

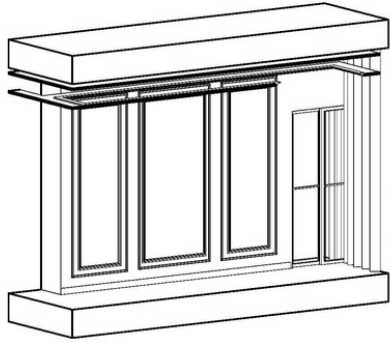

② 1-Entrance hall

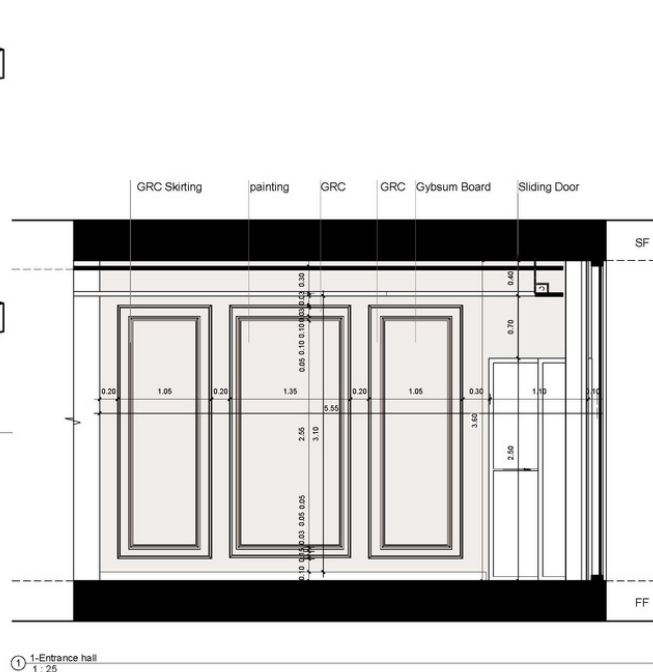

① 1-Entrance hall
1:25

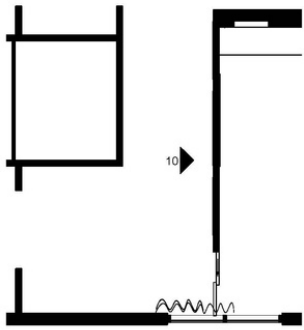

③ 1-Entrance hall
1:40





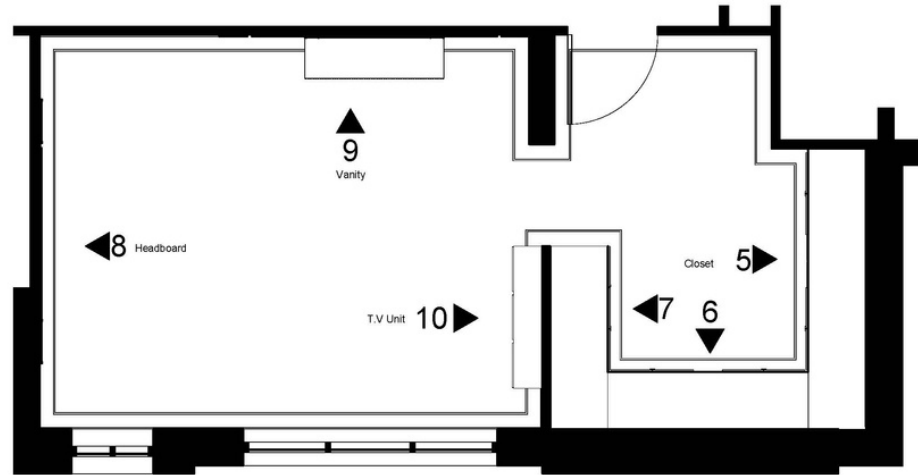

MASTER BEDROOM

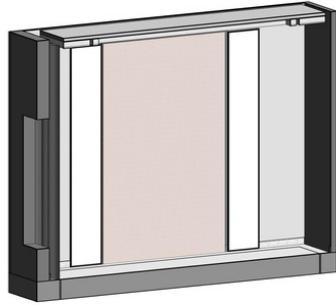

① Headboard

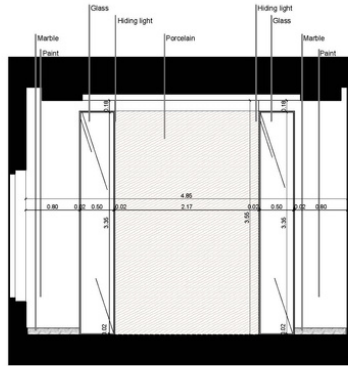

② Headboard
1:25

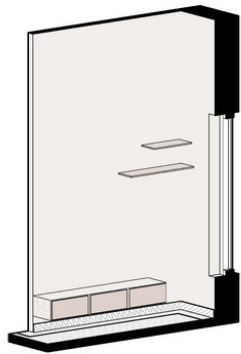

③ TV Unit

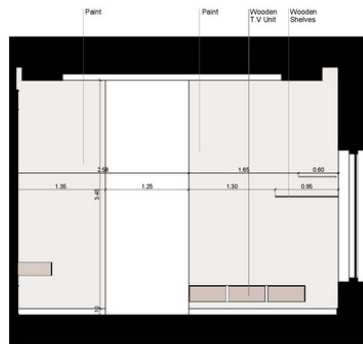

④ TV Unit
1:25



⑤ TV Unit



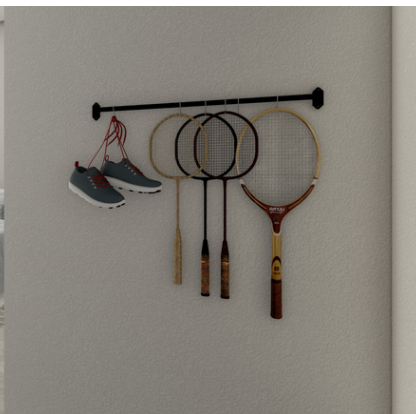

MR.MOHSIN VILLA

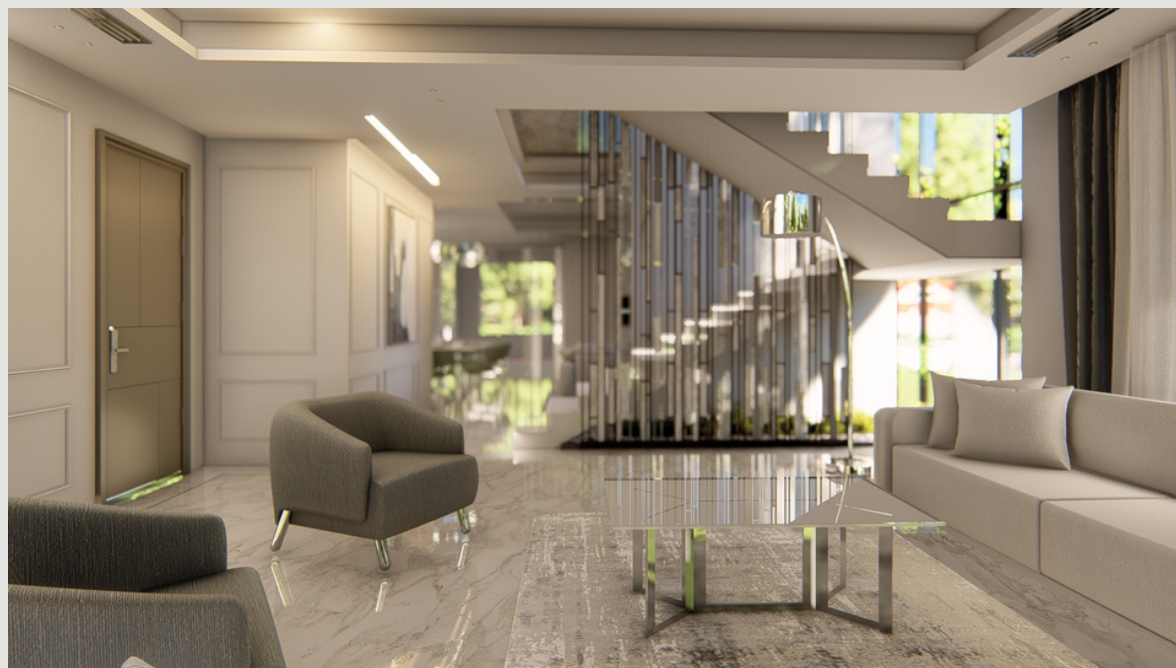

COLOR SCHEME







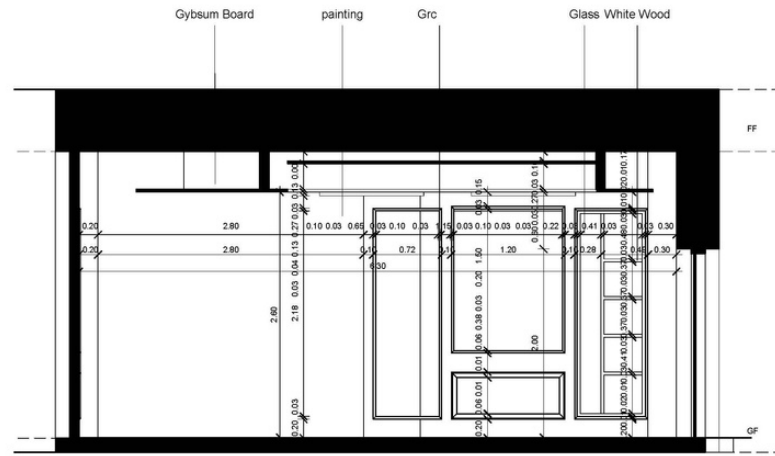

① 1-TV Wall Unit
1:25

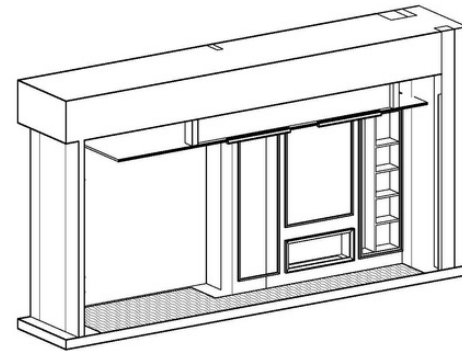

② 1-TV wall unit

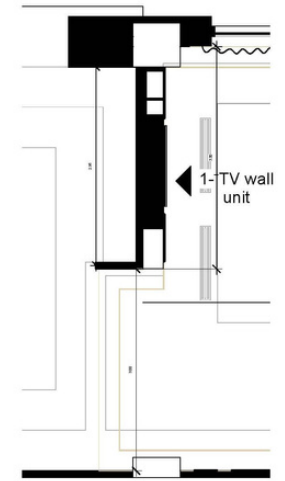

③ 1-TV wall unit
1:35









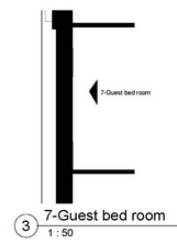
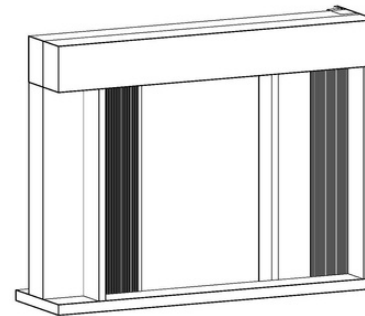
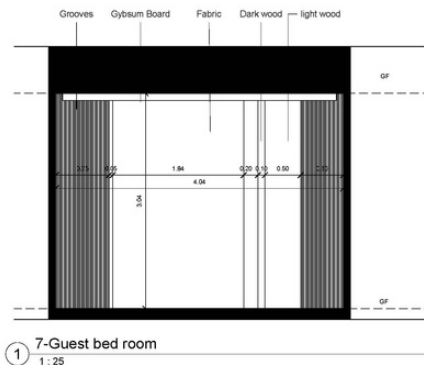













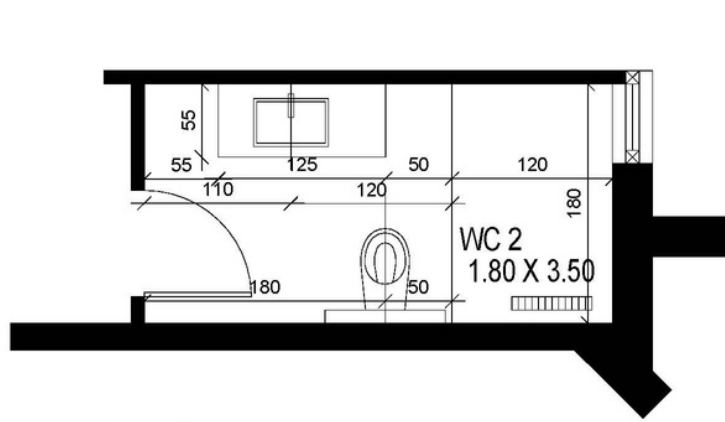

WC 2

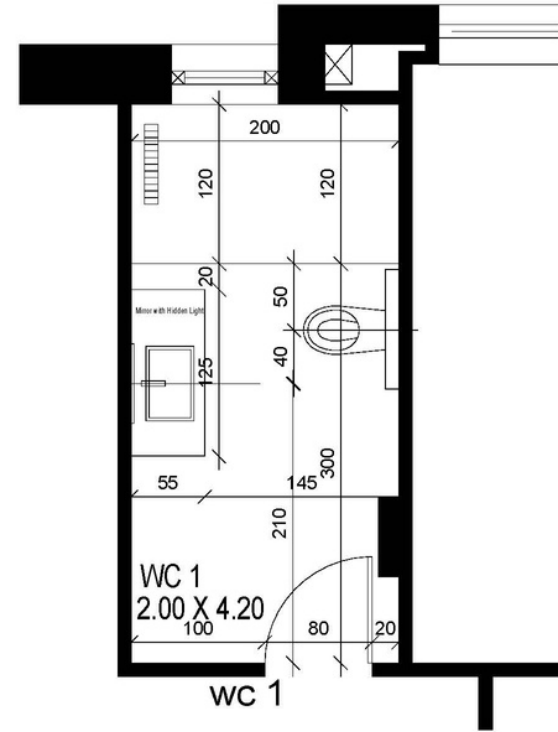

WC 1

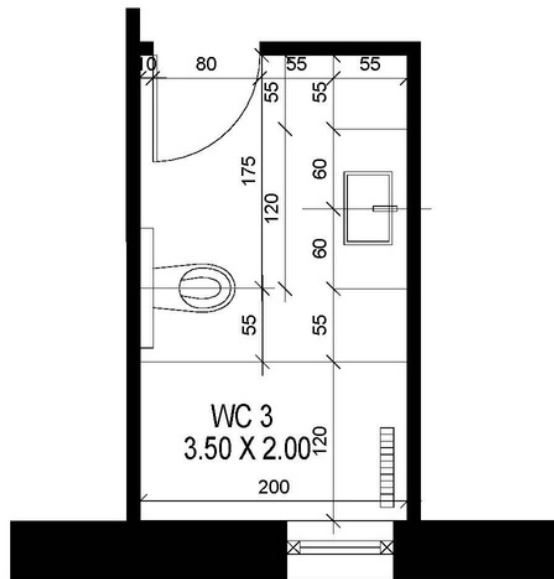

WC 3

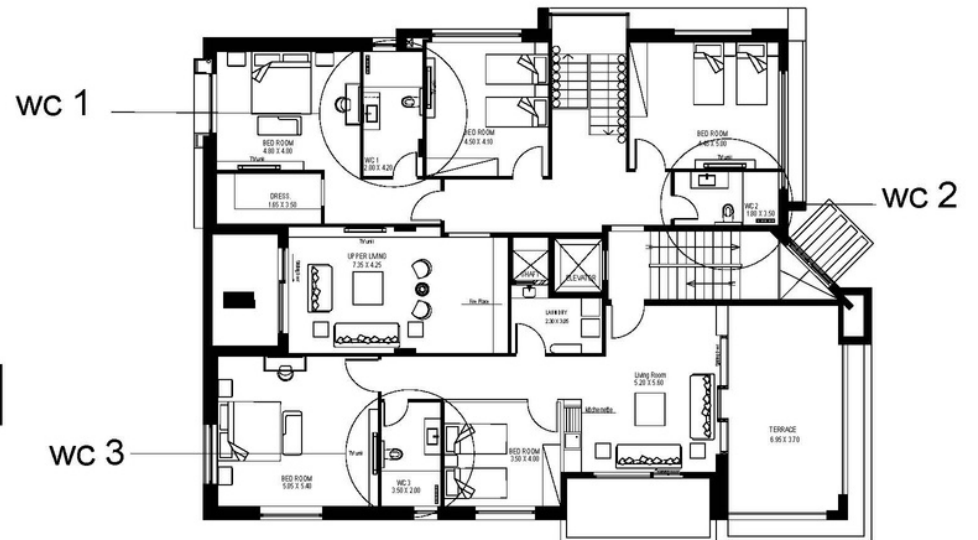



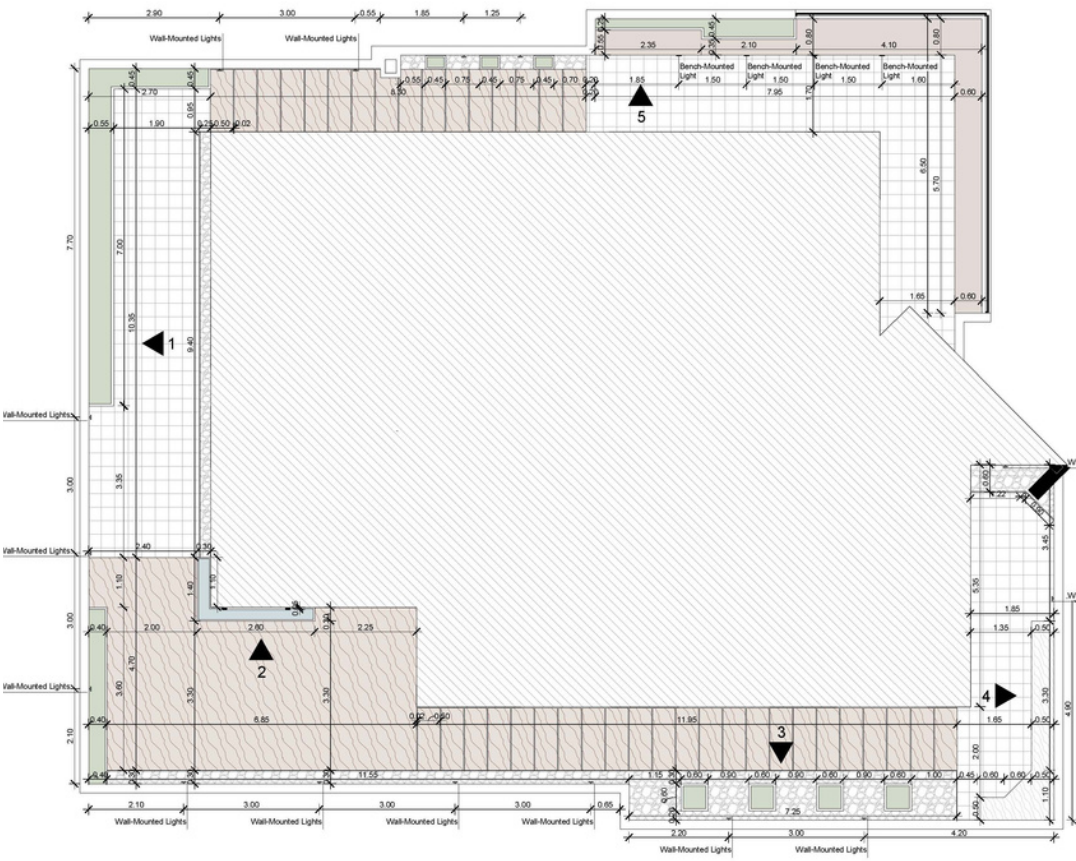



UM AL-ARAYES



COLOR SCHEME





COMMERCIAL PROJECTS INTERIOR DESIGN

LEXUS - AL MARKAZYYEH



COLOR SCHEME

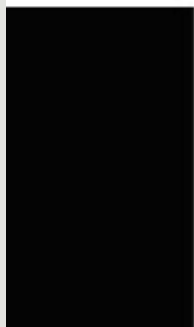





TOYOTA - AL MARKAZYYEH



COLOR SCHEME





DRUG CENTER PHARMACY



COLOR SCHEME

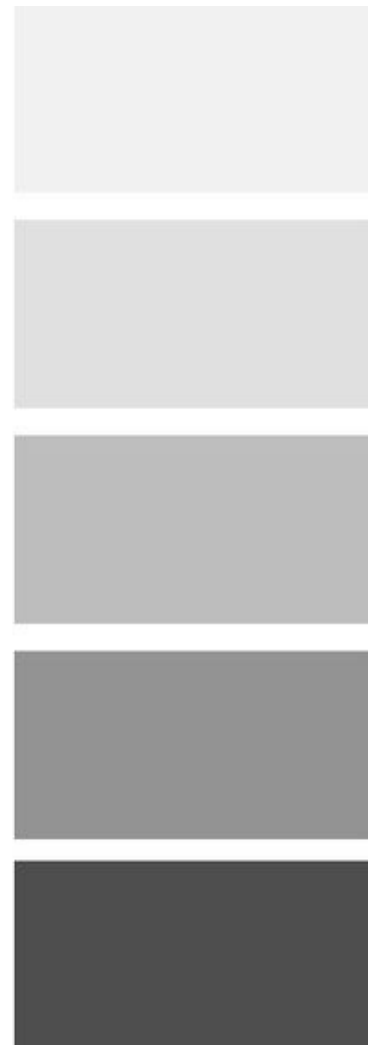

PLAN - AREA

No.	Width	Depth	Rows
1	1.20	0.30	7
2	1.20	0.30	7
3	3.30	0.30	7
4	3.72	0.30	7
5	1.40	0.30	7
6	1.20	0.30	7
7	8.00	0.25	5
8		51 m	
9	0.62	0.25	14
10	5.14	0.25	14
11	0.95	0.25	14
12	1.87	0.25	14
13	1.95	0.25	14
14	2.00	0.25	10
15	1.84	0.25	14
16	1.15	0.25	14
17	3.00	0.30	6
18	2.00	0.30	6
19	3.00	0.30	6
20		45.50 m	
21	0.70	0.20	8
22	2.50	0.50	2



META FORM

CONTACT

E-mail	info@metaformarchitects.com
Website	www.metaformarchitects.com
Phone	0776510947 - 0797372857
Address	dabouq , jreisat plaza 2 , floor 2